



WORK-BRIGHT™

WB-HB-300W



- Work-Bright™ **LUMENTEC**® tuned spectrum
- Color Rendition Index (CRI) > .90
- 100,000 hour life cycle
- 110V~277V or 310V~520V and 50hz or 60hz auto-sensing ballast, .98 power factor
- Instant strike/re-strike, no warm-up/cool down
- Negligible in-rush current
- Nano-particle reflector technology
- **VARI-BEAM**® focus technology
- IP65 rated, WF2 anti-corrosion grade finish

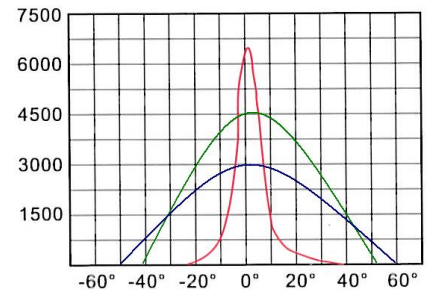
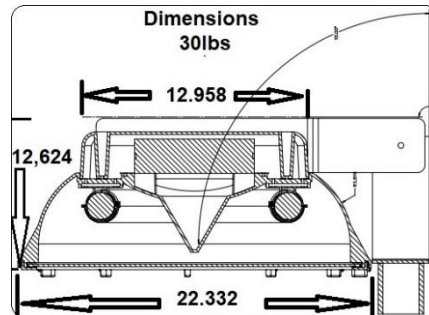

The Work-Bright™ 300-Watt round high-bay is ideal for all types of industrial environments. The unique full spectrum full diffusion fixture is capable of replacing 1,000W metal halide and halogen lamps for energy savings of up to 85%. Unique Vari-Beam® technology allows changing the focal length and light dispersion to provide precision lighting patterns. Ideal for replacing T5 or T8 fluorescent lighting and LEDs that flicker. Ultra-high efficiency driver (ballast) is available in 110V~277V or 310V~520V auto-sensing and 50hz/60hz to meet U.S. and European standards. Super-long lifecycle exceeding 100,000 hours (11 years operating 24hr per day, 365 days per year).



Work-Bright™ light uses Health-Bright™ technology that can actually **improve worker performance and increase overall safety**. Diffused light provides uniformity without hot spots. Instant strike means never having to wait for a warm-up or cool-down. The WB-HB-300W is ideal for extreme environments from -30°F to +140°F with no light degradation or impact upon lifecycle.

Contact: info@teslalightingco.com
28 Church Street, Unit 11, Warwick, NY 10990



TECHNICAL SPECIFICATIONS

MODEL	WB-HB-300W
RATED WATTAGE	300W
VOLTAGE RANGES	120V~277V \pm 15% 310V~520V \pm 15%
CURRENT @ 120V~277V @ 310V~520V	1.105A~2.55A 0.9875A~0.58869A
FREQUENCY	50/60Hz
POWER FACTOR	0.98
IN-RUSH CURRENT	NEGLIGIBLE
RFI PART 15/18	SHIELDED
NOISE	<20dB
TYPE	MAGNETIC INDUCTION
COLOR RENDITION INDEX	>95
COLOR TEMPERATURE	6,500K~10,000K UV TRUNCATED
CERTIFICATIONS	UL/UL-C/CCC/CE/FC/RoHS/CB
B.U.G. RATING	0/0/<110
DARK SKY	COMPLIANT G(0)
CERTIFICATIONS	UL-C/CCC/CE/CB/RoHS
TEMPERATURE RANGE	-30°F ~ +140°F
RATING	IP65
FINISH	POWDER COATED
REFLECTOR	FULL-DIFFUSION NANO-PARTICLE
MOUNTING	PIPE OR FLUSH
FUSES	OPTIONAL 2 HOT FOR 480V
LUMENS PER WATT	80LPW~95LPW
VISUALLY EFFECTIVE LUMENS	~277/LPW

FEATURES	HID	HPS	LED	Work-Bright™	Other MIL
100,000 hour life cycle	No	No	No	YES	Yes
85% energy savings	No	No	Some	YES	Yes
Light-weight	No	No	Some	YES	Some
IP65 Rating, Dust/Chemical Resistant	Some	Some	Some	YES	Some
Proprietary Geometry	No	No	No	YES	No
Instant strike - no warm up or cool down	No	No	No	YES	Yes
Full Spectrum with CRI > .95	No	No	No	YES	Some
Exceptionally high power factor > .95	No	No	Some	YES	Some
Negligible "In-Rush" current	No	No	No	YES	YES
Unparalleled Warranty 5 years/50K hrs	No	No	Some	YES	Some
Fully recyclable, no special disposal	No	No	No	YES	Yes
Lease Financing Available	No	No	No	YES	No

